

ADR

ALCEN

SVM80

New Compact, Rigid and Accurate Hollow Shaft Servomotor
For Defence & Security, Aeronautics, Civil and Scientific Applications

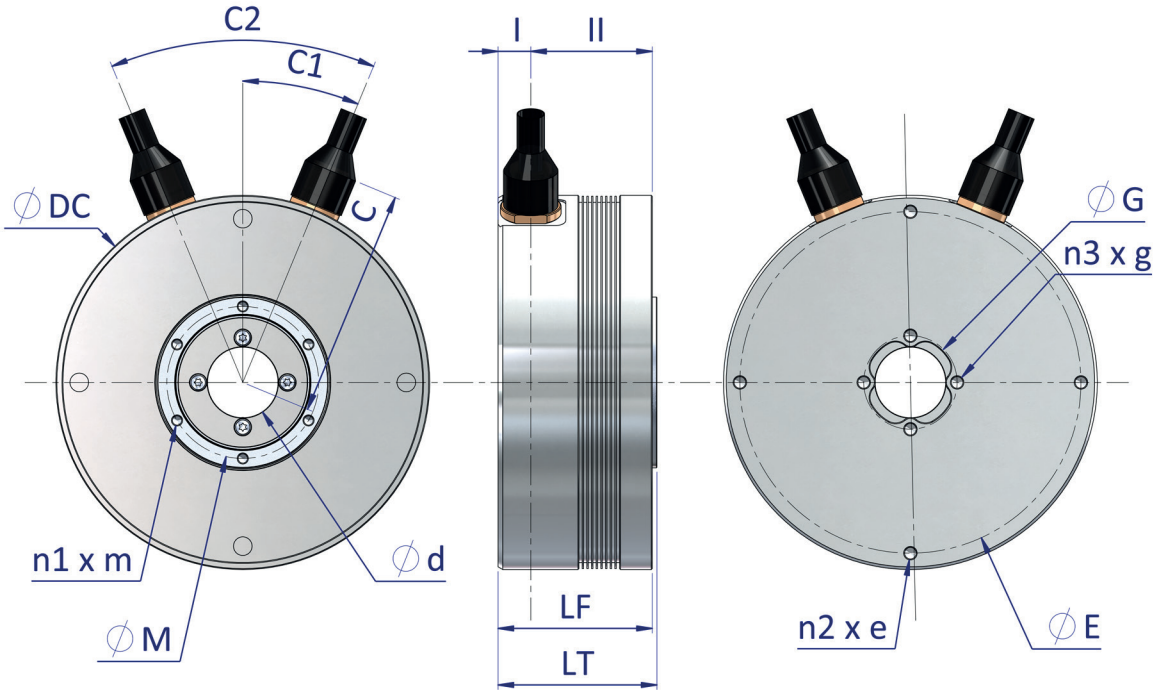

MECHANICAL DATA

V1.23.05

Basic Designation	Dimensions (mm)																Mass* (g)		
	DC	d	M	n1	m	E	n2	e	G	n3	g	LF	LT	C	C1	C2		I	II
SVM80_D_S	80	15	32.5	6	M2.5	73	4	M3	20	4	M3	33	34	47	22.5	45	7	26	650
SVM80_D_L	80	15	32.5	6	M2.5	73	4	M3	20	4	M3	33	34	47	22.5	45	7	26	460

For other fixing dimensions, please contact us.

*Without connection

ADMISSIBLE LOADS AND MOMENT OF INERTIA

Basic Designation	Static Axial Load (N)	Static Bending Moment (N.m)	Rotor Inertia (g.mm ²)
SVM80_D_S	1840	15	593.10 ²
SVM80_D_L			

Admissible loads are given considering fixation on E diameter. For higher loads, please contact us.

ENVIRONMENT

	Minimum Temperature (°C)	Maximum Temperature (°C)
Operating	-40	+85*
Storage	-40	+105

*Maximum operating temperature depending on duty cycle and assembly configuration.

technology in motion

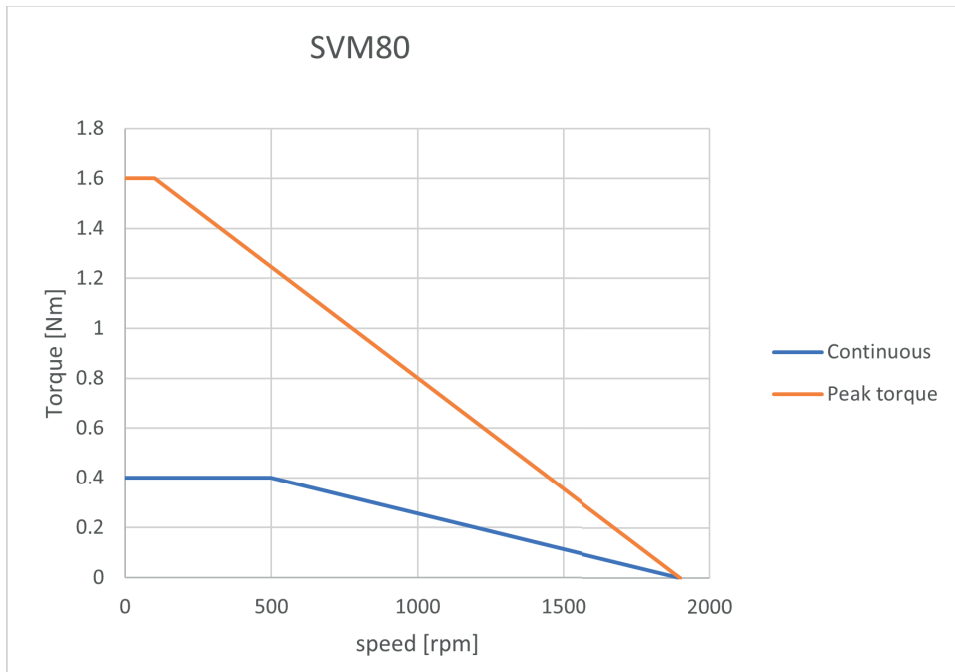

ELECTRICAL DATA

Motor		
DC Voltage	24	V
Continuous Nominal	21	W
Peak Current	10.4	Arms
Nominal Current	2.6	Arms
Insulation Class	F	
Terminal Cross Section	22	AWG
Type of Connections	Flying leads, min. length 300 mm	

For further information, please contact us.

Encoder		
Type	Absolut	
Binary Resolution	Up to 19	bits
Accuracy	$\pm 0.010^\circ$	
Supply Voltage	5 ± 0.5	V
Communication Protocol	BiSS	
Serial Output	Differential RS-422	
Clock	Differential RS-422	
Terminal Cross Section	26	AWG
Type of Connections	Flying leads, min. length 300 mm	

For further information, please contact us.



ALCEN

6 rue Paul Baudry
75008 Paris – FRANCE
Tel. + 33 (0)1 40 72 55 00
alcen@alcen.com
www.alcen.com

ADR

12 Chemin des Prés
77810 Thomery - FRANCE
Tel. +33 (0)1 64 70 59 50
mail@adr-alcen.com
www.adr-alcen.com